



1217 E. 7th Street
Mishawaka, IN 46544
Phone: 1-800-334-4712
1-888-339-2539
Fax: 574-256-6743

T.I.P. Troubleshooting Information on Power Gear

SYNCHRONIZING A 2 RAIL SLIDE-OUT ROOM

Should the slide-out room go out of synchronization this procedure will allow you to retime the room. Measure room synchronization from common solid points at each end of the room.

NOTE- This Tip Sheet does cover standard and flat floor slide-out systems.

To synchronize the room please refer to the Figure below.

TIMING SLIDE-OUT RAILS

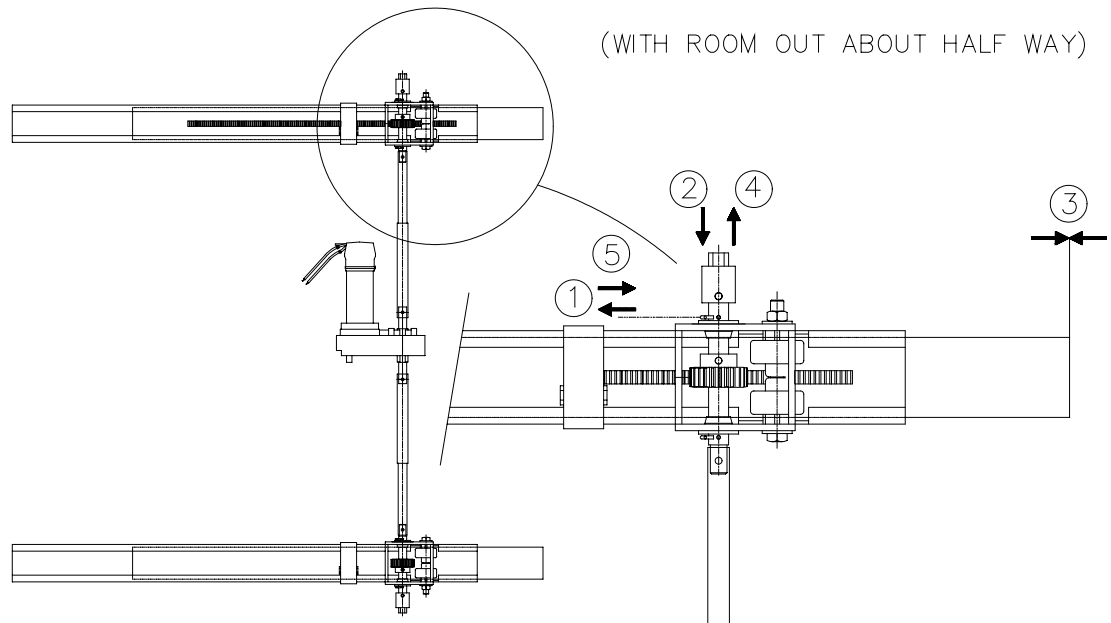

With room about half way our release slide-out motor brake.

1. Pull the clip pin out.
2. Slide the drive shaft assembly in to disengage gear from gear rack.
3. Moved slide-out inner rail in/out to desired location.
4. Slide drive shaft assembly back into position.
5. Push clip pin back into shaft.

Before proceeding put slide-out motor brake lever back into "Engaged" position.